



UNIVERSITY OF CAMBRIDGE INTERNATIONAL EXAMINATIONS
International General Certificate of Secondary Education

CANDIDATE
NAME

CENTRE
NUMBER

--	--	--	--	--

CANDIDATE
NUMBER

--	--	--	--



DESIGN AND TECHNOLOGY

0445/41

Paper 4 Systems and Control

October/November 2012

1 hour

Candidates answer on the Question Paper.

No Additional Materials are required.

To be taken together with Paper 1 in one session of 2 hours and 15 minutes.

READ THESE INSTRUCTIONS FIRST

Write your Centre number, candidate number and name on all the work you hand in.

Write in dark blue or black pen.

You may use a soft pencil for any diagrams or graphs.

Do not use staples, paper clips, highlighters, glue or correction fluid.

DO NOT WRITE IN ANY BARCODES.

You may use a calculator.

Section A

Answer **all** questions.

Section B

Answer **one** question.

At the end of the examination, fasten all your work securely together.

The number of marks is given in brackets [] at the end of each question or part question.

For Examiner's Use	
Section A	
Section B	
Total	

This document consists of an **16** printed pages.



Section A

Answer **all** questions in this section.

1 Fig. 1 shows a building site.

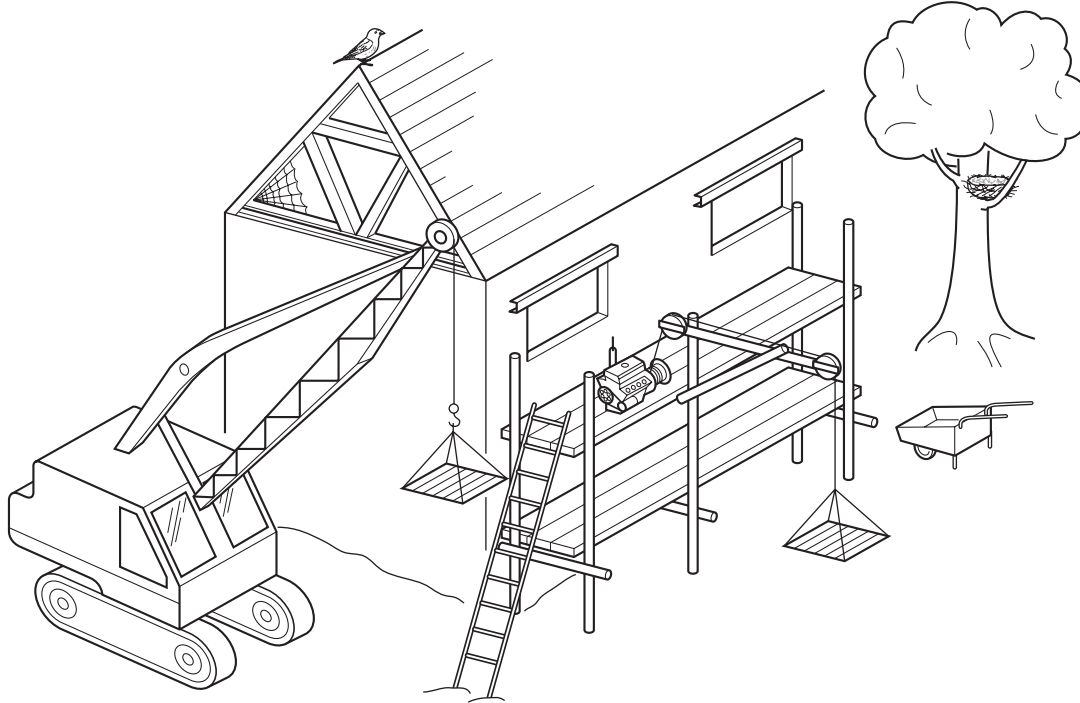

Fig. 1

Identify **one** man-made and **one** natural structure in Fig. 1.

Man-made structure:

..... [1]

Natural structure:

..... [1]

2 Fig. 2 shows four cross-sections of material found on a building site.

Name the four cross-sections shown.



(a) (b) (c) (d)

Fig. 2

[4]

3

3 Fig. 3 shows four designs for frameworks.

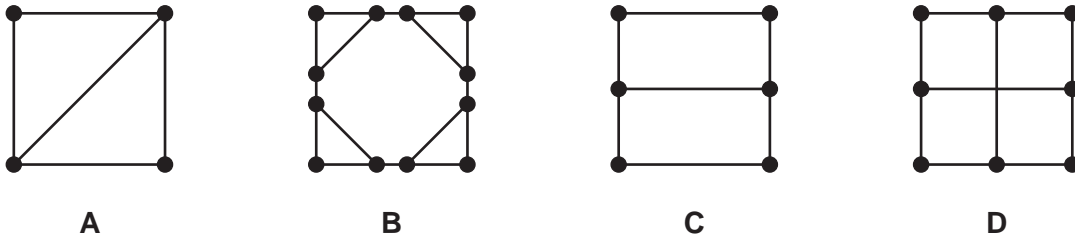

Fig. 3

(a) Identify the framework that best uses members for rigidity.

..... [1]

(b) State the name of a framework member that serves no structural purpose within a structure.

..... [1]

4 Fig. 4 shows a loaded wheelbarrow.



Fig. 4

Indicate on Fig. 4 the load, the effort and the fulcrum. [3]

5 Explain the meaning of the term *mechanical advantage*.

.....
.....
..... [3]

6 Fig. 5 shows the drive mechanism of a lawn mower.

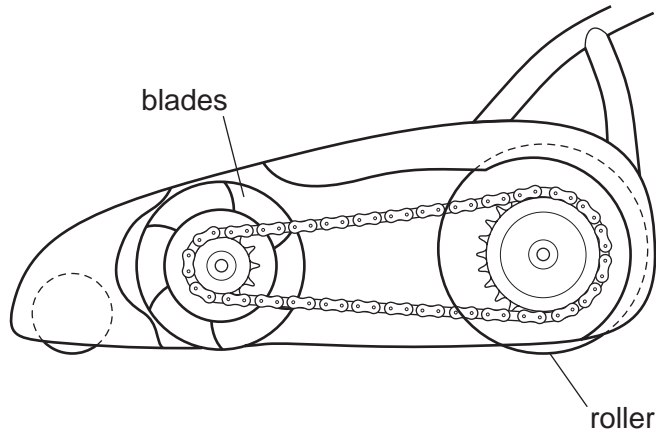

Fig. 5

(a) Name the type of drive mechanism shown in Fig. 5.

..... [1]

(b) State **one** benefit of this type of mechanism.

..... [1]

(c) Give **one** reason why it is important to lubricate mechanisms.

..... [1]

7 Fig. 6 shows a circuit design for a kitchen timer.

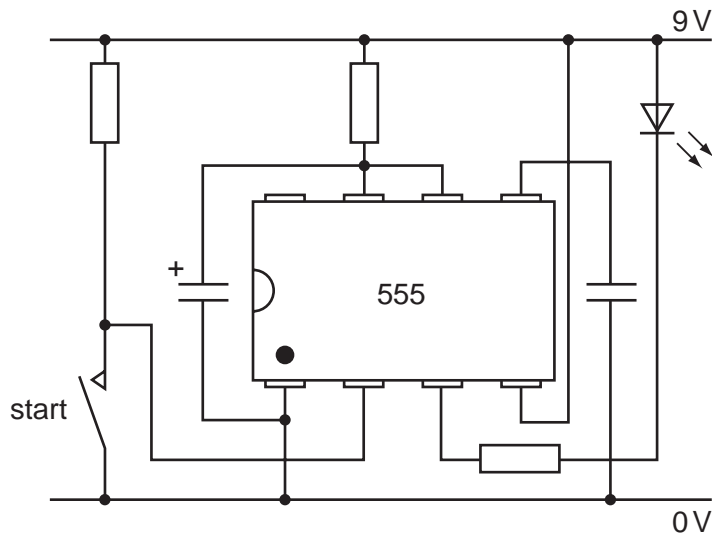

Fig. 6

(a) Give **one** benefit of using the 555 IC in this application.

..... [1]

(b) Name the output device shown in Fig. 6.

..... [1]

(c) Give **one** benefit and **one** drawback of using this output device for a kitchen timer.

Benefit [1]

Drawback [1]

8 Sketch and label the circuit symbol for a relay.

[2]

9 Sketch the circuit symbol for a NOT logic gate.

[2]

Section B

Answer **one** question from this section.

10 Fig. 7 shows a model car.

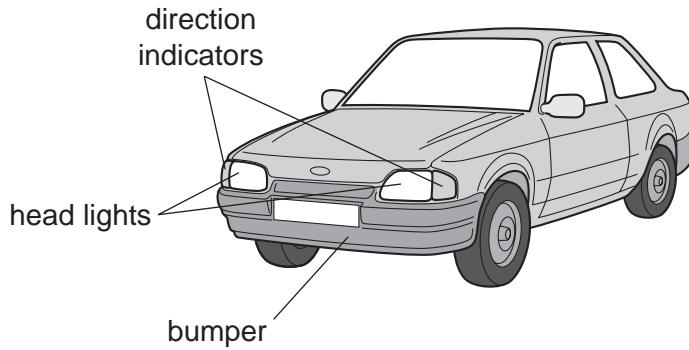
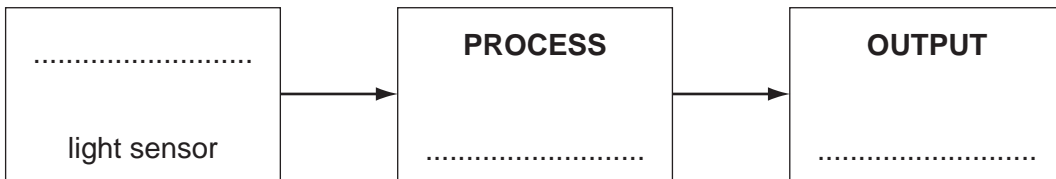

Fig. 7

(a) The head lights on the model car only come on when the car is in darkened conditions.

Complete the block diagram below to show a system to perform this function.



[3]

(b) (i) Name a suitable light sensor that can be used.

..... [1]

(ii) The front lights use standard 60 mA, 4.5 V lamps.

Calculate the power rating for one lamp.

[3]

- (iii) The power source for the lamps is a 9 V battery.

Use a sketch to show how the lamps and battery would need to be arranged.

[2]

- (iv) Draw the circuit diagram of a simple circuit that could be used to turn the head lights on in the dark. You should include the light sensor you have named in **(b)(i)**.

[5]

(c) It is decided to add a sound feature to the model car. When the car bumper touches an obstacle a buzzer will sound. The buzzer switches off when the bumper is released.

(i) Name **two** types of switch that could be placed in the bumper to trigger a buzzer circuit.

1

2 [2]

(ii) Draw the circuit symbol for **one** of the switches you have named.

[1]

(d) The model car is modified to switch on the direction indicators when the bumper switch is pressed and it is dark.

- The bumper switch gives a logic 1 signal when pressed.
- The light sensor circuit gives a logic 0 signal when it is dark.

(i) Draw a logic circuit that will detect these two conditions and will output a logic 1 signal to switch on the direction indicators.

[5]

(ii) Draw the truth table for this circuit.

[3]

11 (a) Fig. 8 shows a two-dimensional card model of an adjustable lamp.

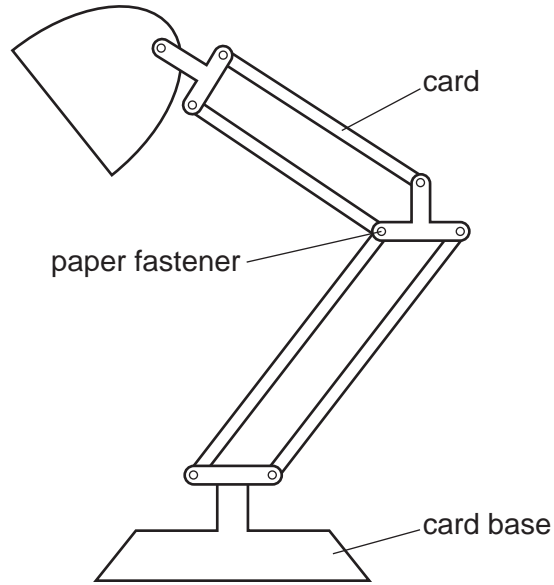

Fig. 8

(i) Give **two** reasons why making a model could help in developing the design of the lamp.

1 [1]

2 [1]

(ii) Name **one** other method of modelling the lamp.

..... [1]

(iii) Name the type of mechanism shown.

..... [1]

(iv) Label **one** fixed pivot and **one** moving pivot on Fig. 8.

[2]

(b) Fig. 9 shows a design for a hand-held mechanical toy.

By moving the tail, the head will move as shown.

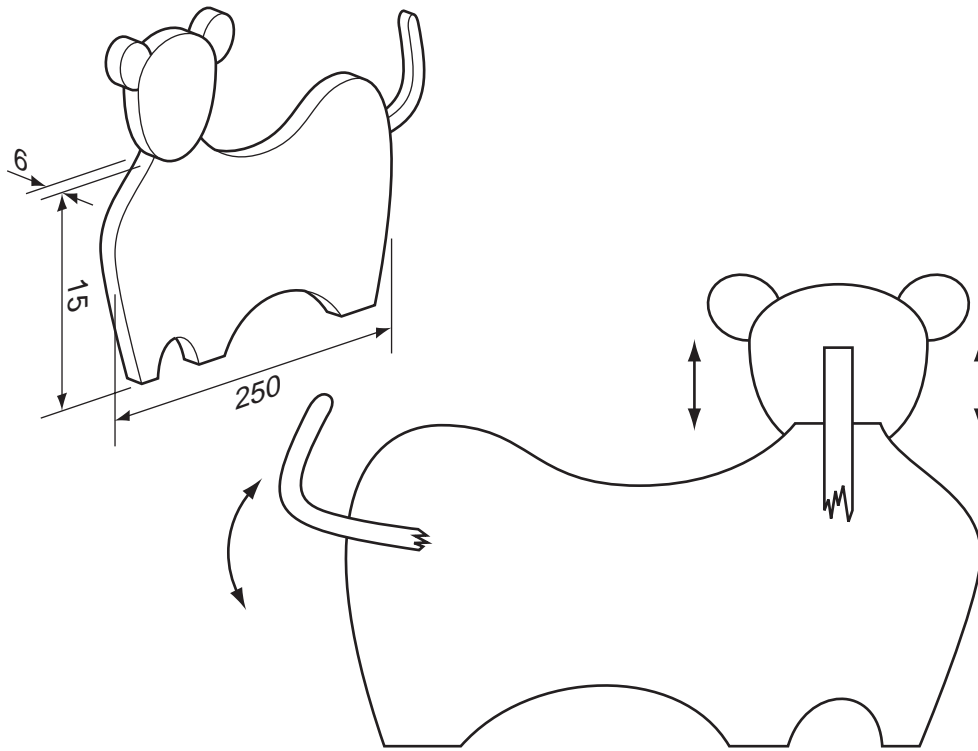

reverse view of hand-held toy

Fig. 9

(i) State the type of motion made by:

- 1 the head [1]
- 2 the tail [1]

(ii) Add sketches and notes to Fig. 9 to show details of a mechanism that would achieve the motion conversion required.

The sketches and notes should clearly show:

- details of the connecting pieces and pivots;
- a method of limiting the distance moved by the head.

[5]

(c) Fig. 10 shows a mobile crane used to transport boats.

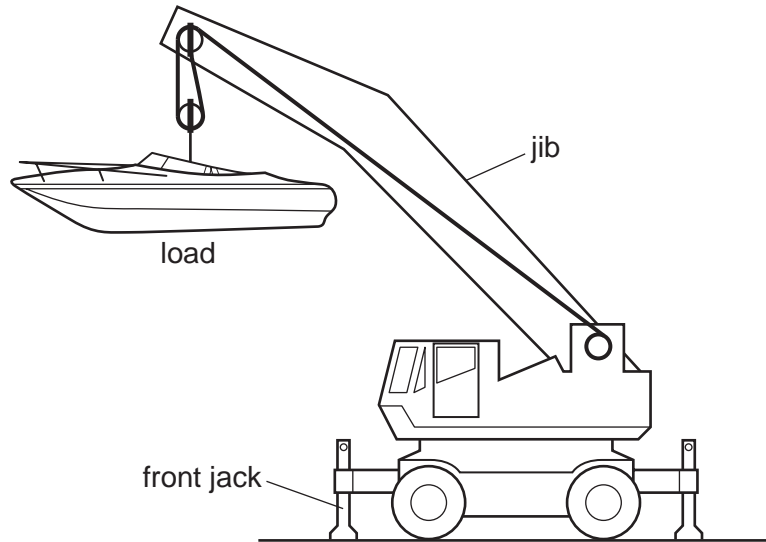

Fig. 10

(i) Name the force present within the ropes of the pulley system.

..... [1]

(ii) Name the force present in the front jack.

..... [1]

(iii) State the velocity ratio of the pulley system shown in Fig. 10.

..... [1]

(d) The efficiency of the pulley system is 90%.

(i) Give the formula used for calculating the mechanical advantage of the system.

..... [1]

(ii) Calculate the mechanical advantage of the system.

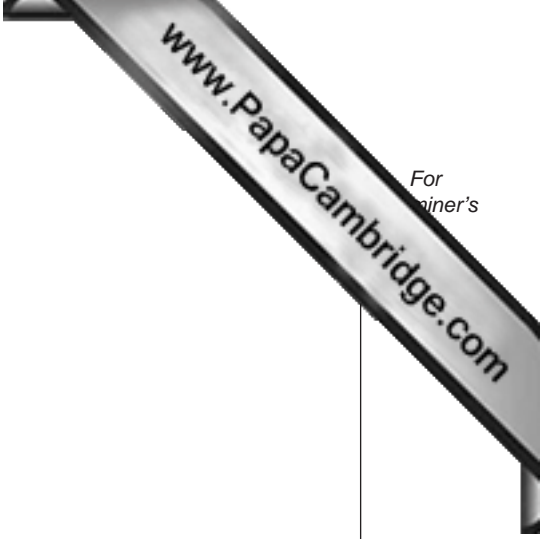

- (e) Give **one** reason why the efficiency is not 100%.

.....

- (f) Fig. 11 shows the arrangement for the winding drum on the mobile crane, driven by a simple pulley system.

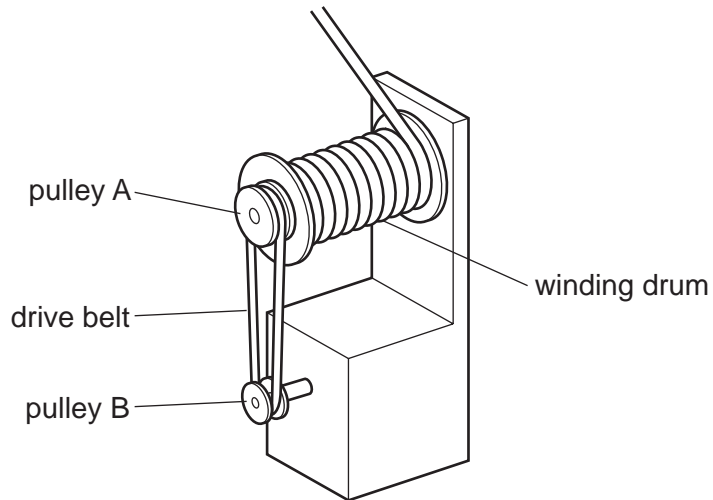

Fig. 11

The drive belt is found to slip. Use sketches and notes to show a method of reducing belt slip.

12 Fig. 12 shows a portable bench.



Fig. 12

(a) Consider the loading on the bench if a person sits at the centre of the bench.

- (i) Show, on Fig. 12, the position of tensile forces and compressive forces acting on the bench. [3]
- (ii) Fig. 13 and Fig. 14 show two cross-sections of two ways of making the wooden seat. [3]

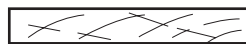

Fig. 13

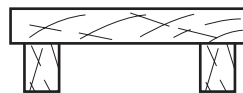

Fig. 14

Explain why the section shown in Fig. 14 is more structurally sound than the section shown in Fig. 13.

.....

.....

.....

..... [3]

(iii) Fig. 15 shows a design for a foot stool.

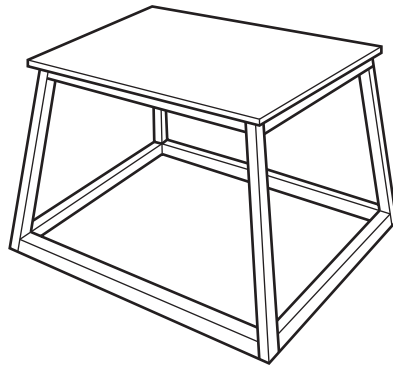

Fig. 15

Explain why the foot stool has been made with the base wider than the top.

.....
.....
..... [2]

(b) Fig. 16 shows the outline of a tubular framework for a temporary outdoor platform.

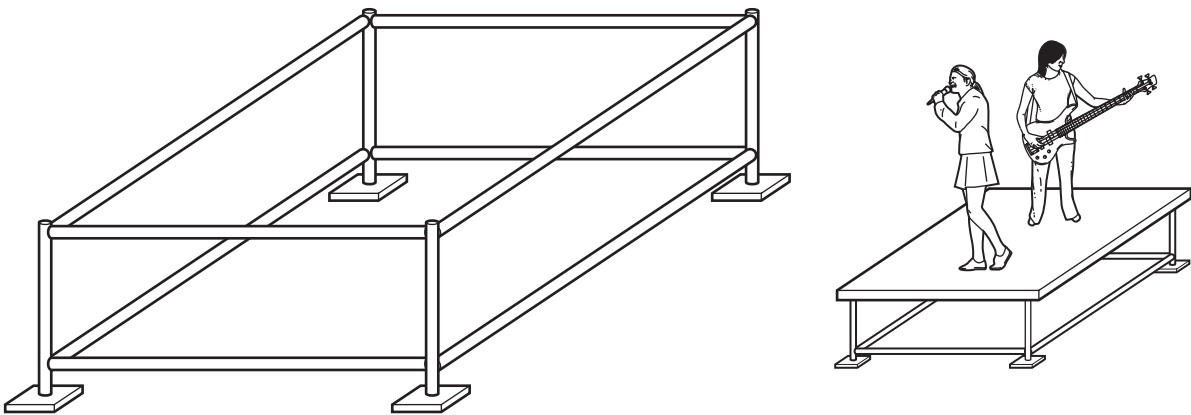

Fig. 16

(i) Use sketches to show how the framework could be modified to improve its rigidity when people move about on the platform.

- (ii) Use sketches and notes to show a joining method that could be used on the framework, so that it is easy to put together and take apart.

[3]

- (iii) Fig. 17 shows an enlarged view of one foot of the framework.

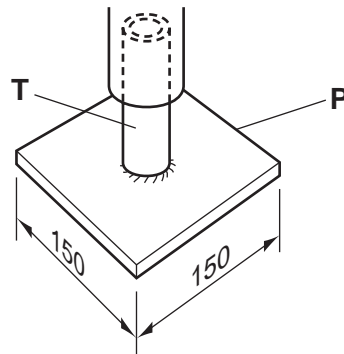

Fig. 17

Explain the purpose of the plate **P** of the foot.

.....

.....

..... [3]

- (iv) If the force on the plate is 1 kN and the plate measures 150 mm × 150 mm, calculate the pressure exerted on the ground.

[2]

- (v) Plate **P** is permanently joined onto the tube **T** of the foot by welding.

State **one** temporary method that could be used to join the plate **P** to the tube **T**.

..... [1]

- (vi) Give **one** other specific example of the use of the method you have stated in part (v).

..... [1]

(c) Fig. 18 shows a design for a toy boat hull.

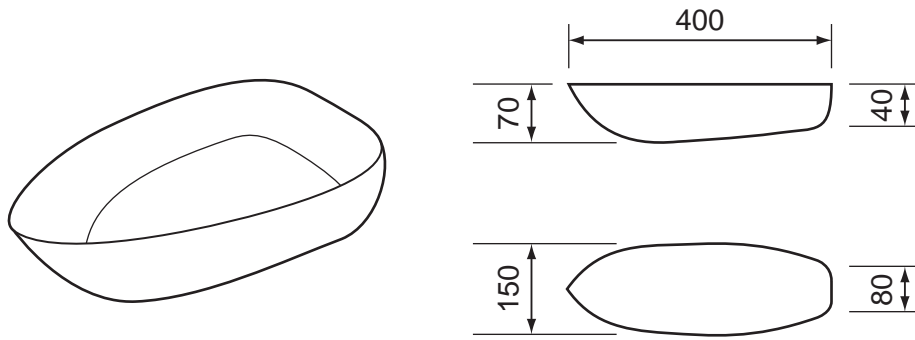

Fig. 18

(i) Name the type of structure of the toy boat hull.

..... [1]

(ii) The toy boat hull is found to be too flexible.

Explain, using sketches and notes, how it would be made more rigid.

[4]